



**Whitehall Manufacturing®**  
Manufacturer of Healthcare and Rehabilitation Products since 1946

## **Dignity Suite™ Recessed Shelf Assembly**

LIGATURE RESISTANT RECESSED CORTERRA™  
SOLID SURFACE SHELF ASSEMBLY



*(Shown mounted vertically)*  
**WHD-SHV10**



*(Shown mounted vertically)*  
**WHD-SHV15**



## D-SHV10 TECHNICAL DIMENSIONS

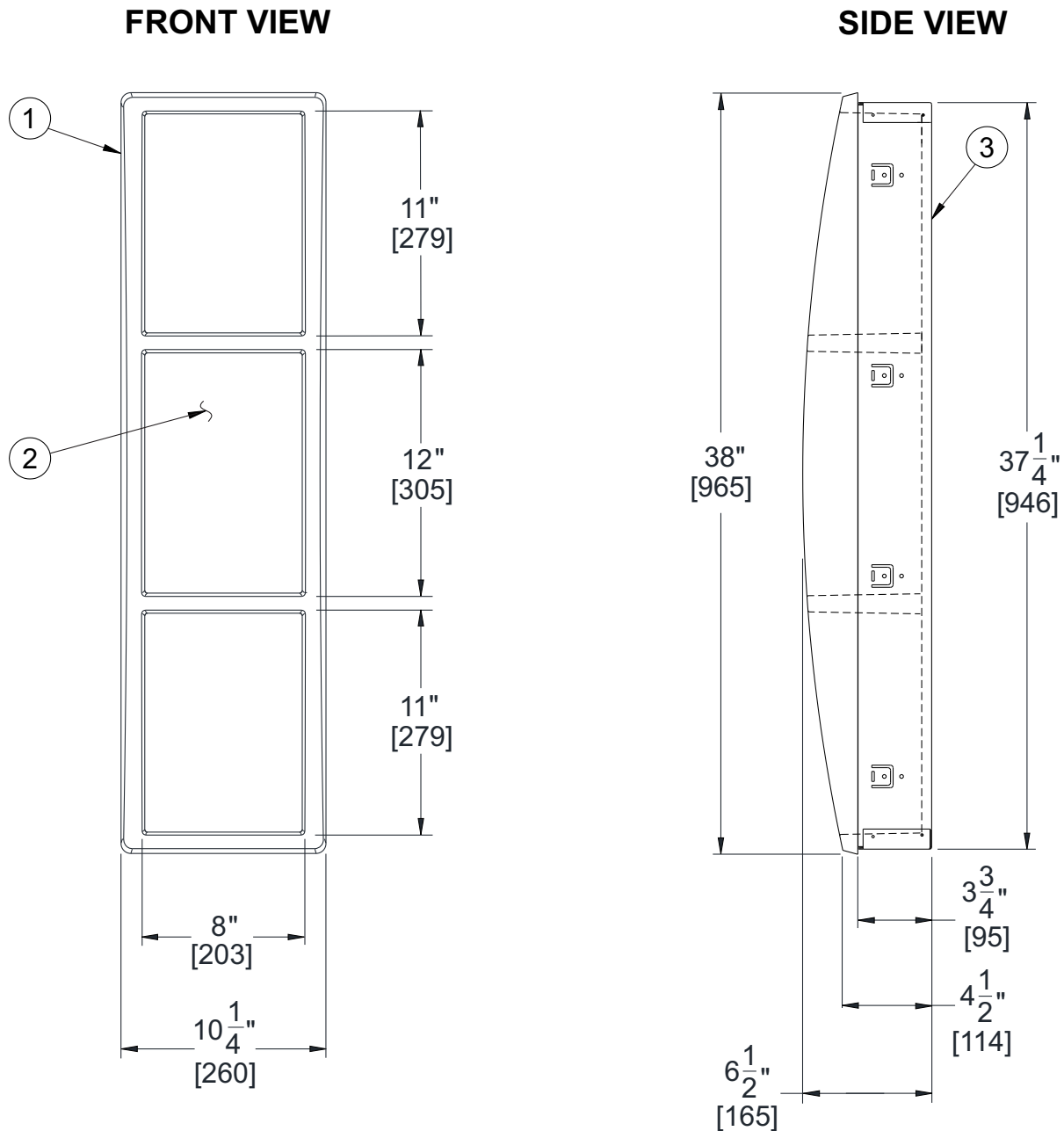

NOTES:

1. SHELF FRAME ASSEMBLY
2. SHELF BACK PANEL
3. MOUNTING FRAME ASSEMBLY



## D-SHV15 TECHNICAL DIMENSIONS

FRONT VIEW

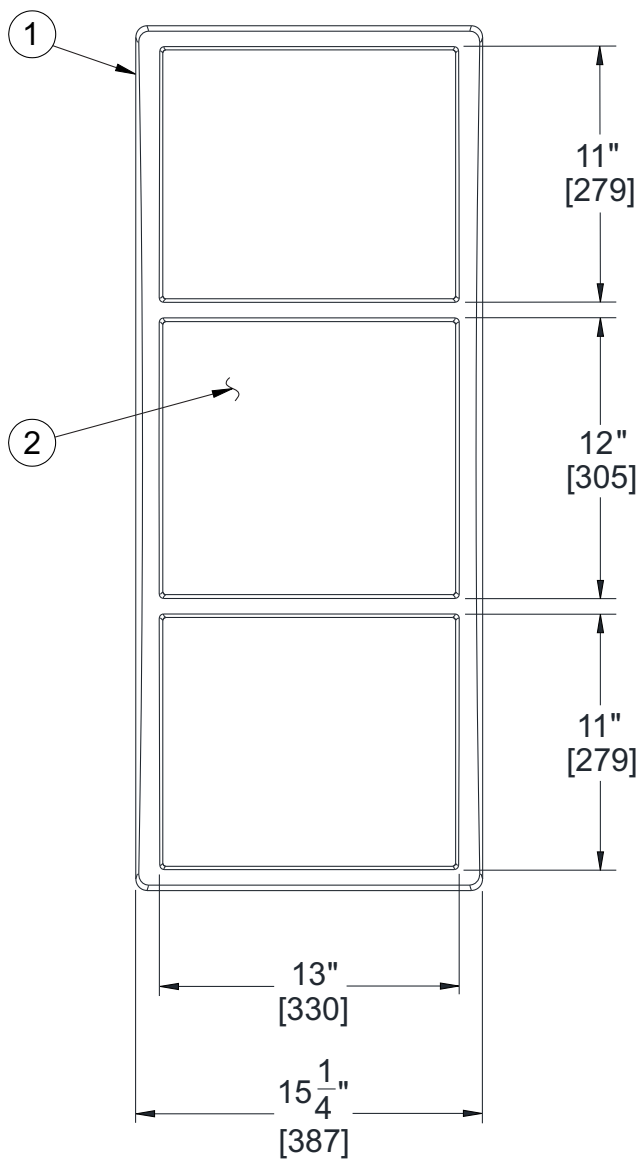

SIDE VIEW

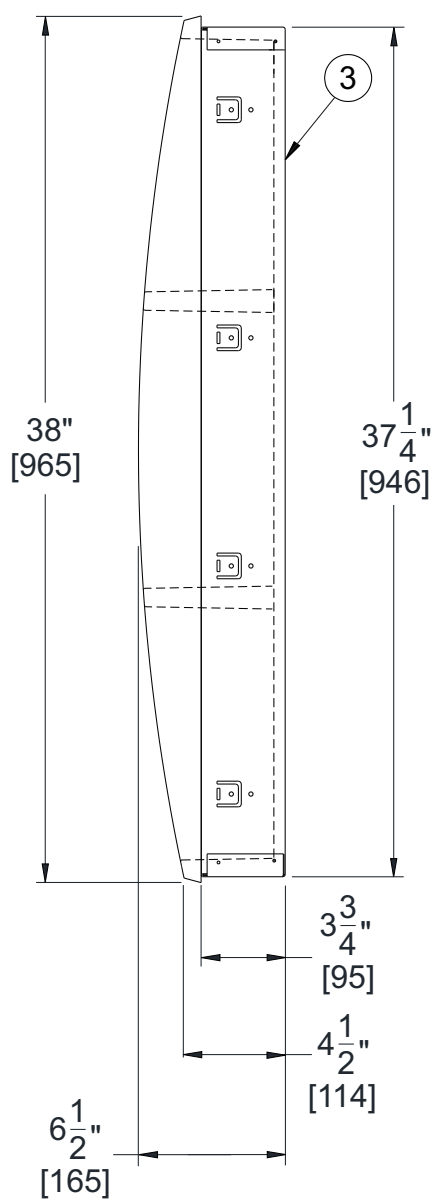

NOTES:

1. SHELF FRAME ASSEMBLY
2. SHELF BACK PANEL
3. MOUNTING FRAME ASSEMBLY



# D-SHV10 FIXTURE ANCHORING

**1** Install 10" x 38" Mounting Frame Assembly into Blockout Area and Secure using Installer Provided Fasteners (12) Places. Ensure frame is level.

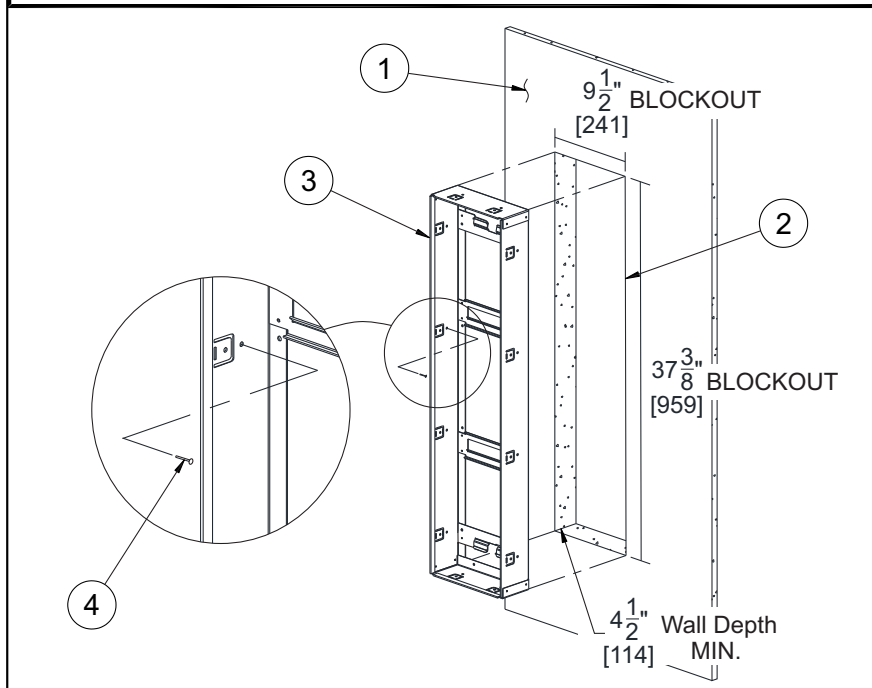

**NOTE:** Accessibility standards may dictate shelf height for reach range. Verify requirements.



- 1 Finished Wall
- 2 Blockout Area
- 3 Mounting Frame Assembly
- 4 Installer Provided Fasteners to suit wall conditions

**2** Install Shelf Frame Assembly into Mounting Frame Assembly and ensure Middle Mounting Clips engage.

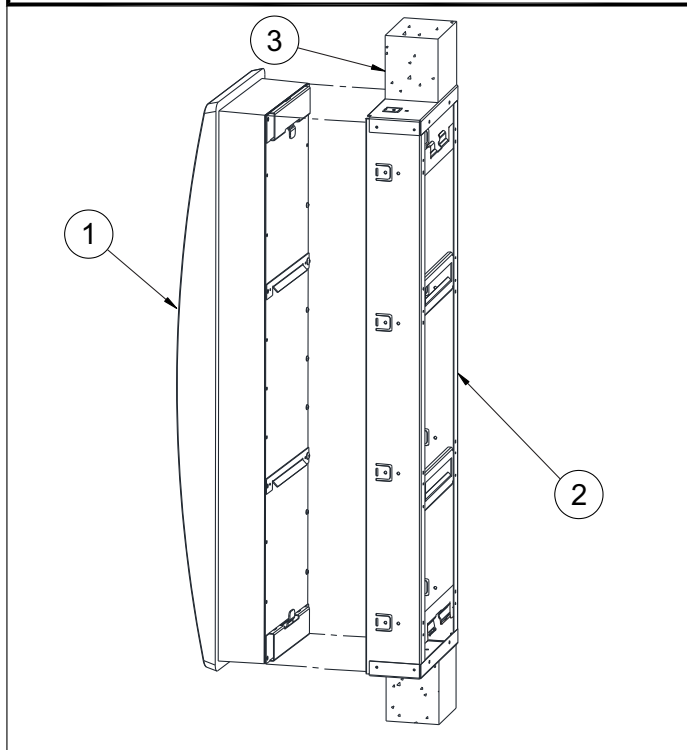

- 1 Shelf Frame Assy.
- 2 Mounting Frame Assy.
- 3 Finished Wall



# D-SHV10 FIXTURE ANCHORING

**3** Align the Back Panel Mounting Clips onto Top and Bottom the Frame Mounting Channels and ensure the Magnetic Latch is at the starting position. Ensure Middle Mounting Channels align with Back Panel Mounting Channels.

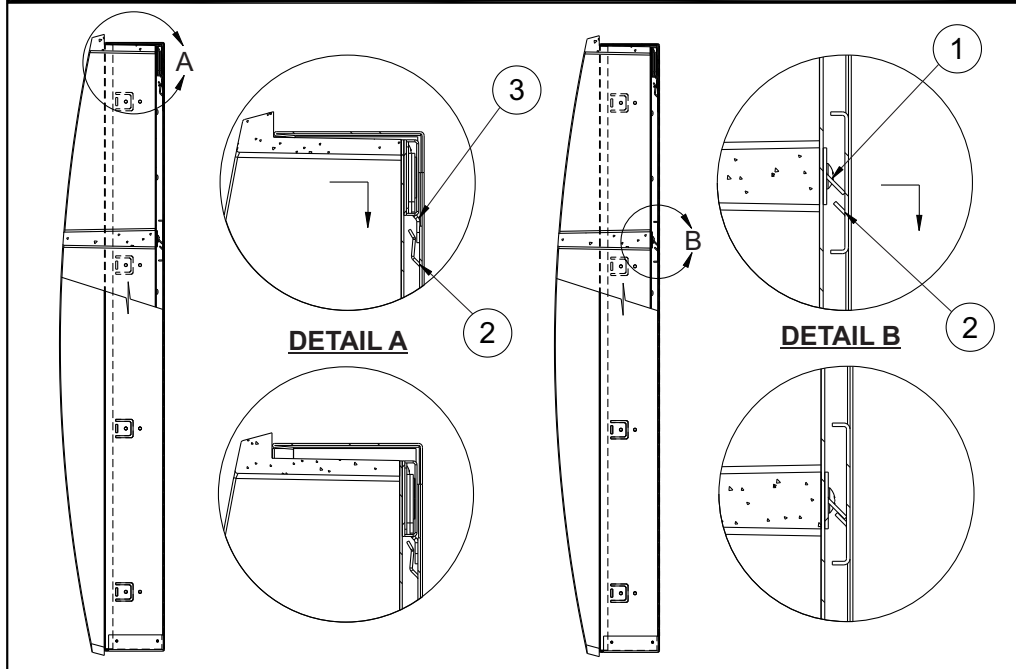

- 1 Back Panel Mounting Clip
- 2 Frame Mounting Channel
- 3 Magnetic Latch

**NOTE: IF MOUNTED HORIZONTALLY, USE MAGNET KEY TO ENGAGE LATCH AND MOVE TOWARDS THE DIRECTION OF GRAVITY TO ENSURE THE FIXTURE IS SECURE.**

**4** Secure Magnetic Latch using Magnet Key (Provided) by engaging Latch and moving it in one of two directions depicted by the arrows below.

### FRONT VIEW

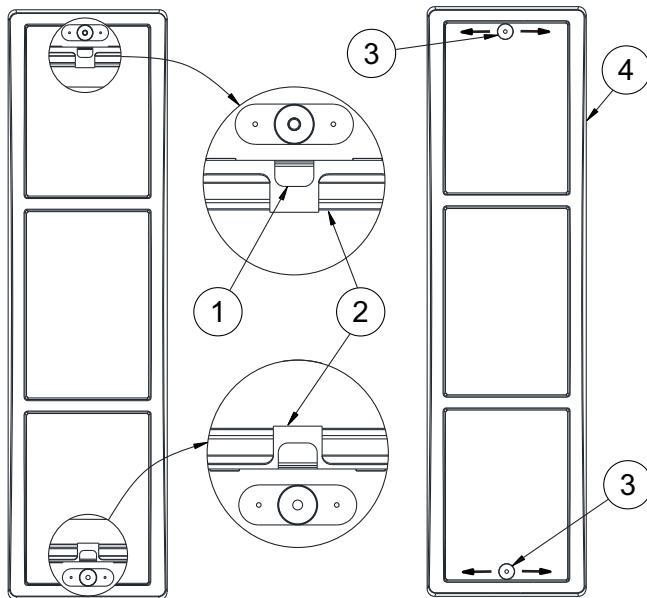

- 1 Magnetic Latch
- 2 Frame Mounting Channel
- 3 Magnet Key (Provided)
- 4 Shelf Assembly

MAGNET KEY  
(PROVIDED)

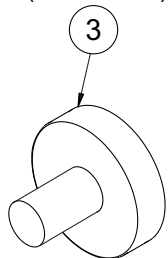

(NOT TO SCALE)



# D-SHV15 FIXTURE ANCHORING

**1** Install 15" x 38" Mounting Frame Assembly into Blockout Area and Secure using Installer Provided Fasteners (12) Places. Ensure frame is level.

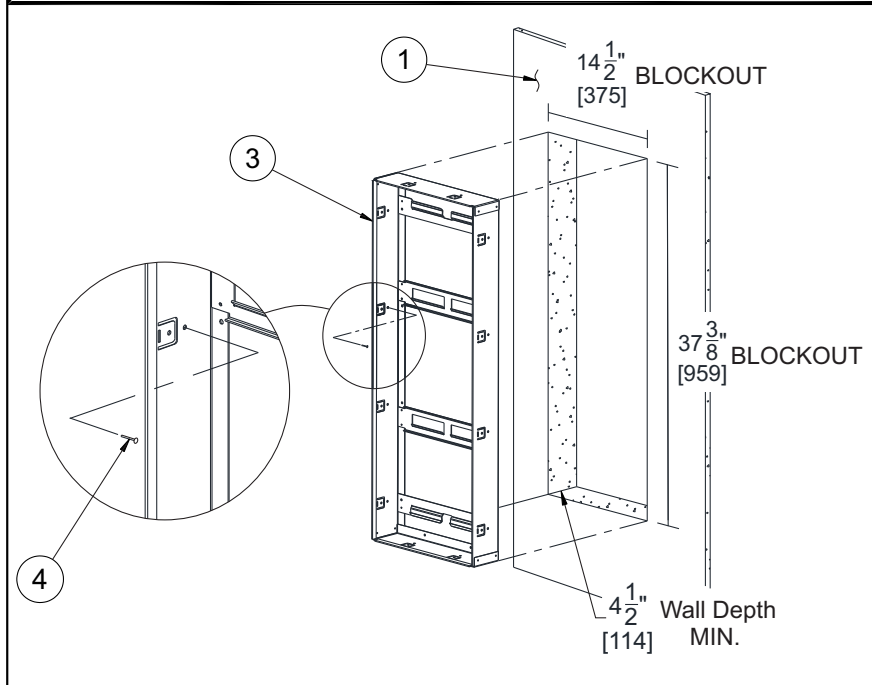

**NOTE:** Accessibility standards may dictate shelf height for reach range. Verify requirements.



- 1 Finished Wall
- 2 Blockout Area
- 3 Mounting Frame Assembly
- 4 Installer Provided Fasteners to suit wall conditions

**2** Install Shelf Frame Assembly into Mounting Frame Assembly and ensure middle Mounting Clips Engage.

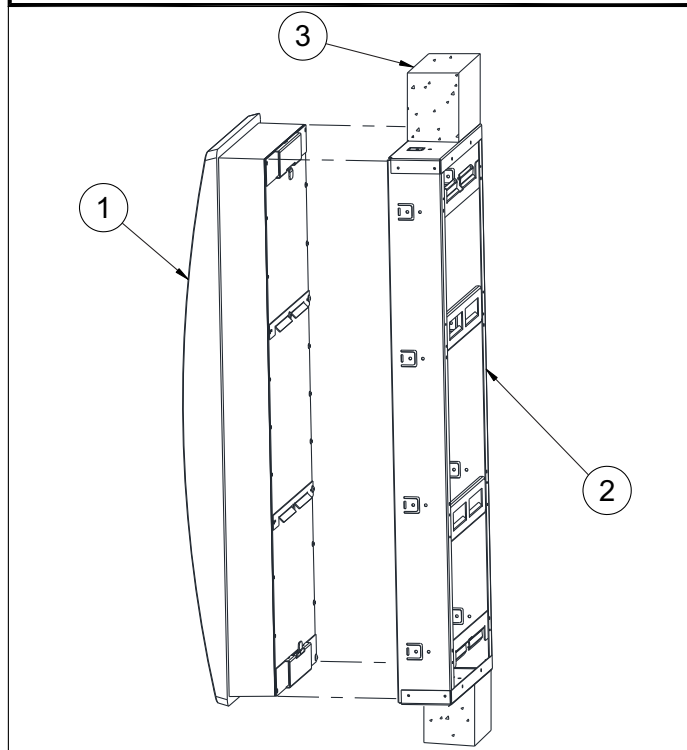

- 1 Shelf Frame Assy.
- 2 Mounting Frame Assy.
- 3 Finished Wall



# D-SHV15 FIXTURE ANCHORING

**3** Align the Back Panel Mounting Clips onto Top and Bottom the Frame Mounting Channels and ensure the Magnetic Latch is at the starting position. Ensure Middle Mounting Channels align with Back Panel Mounting Channels.

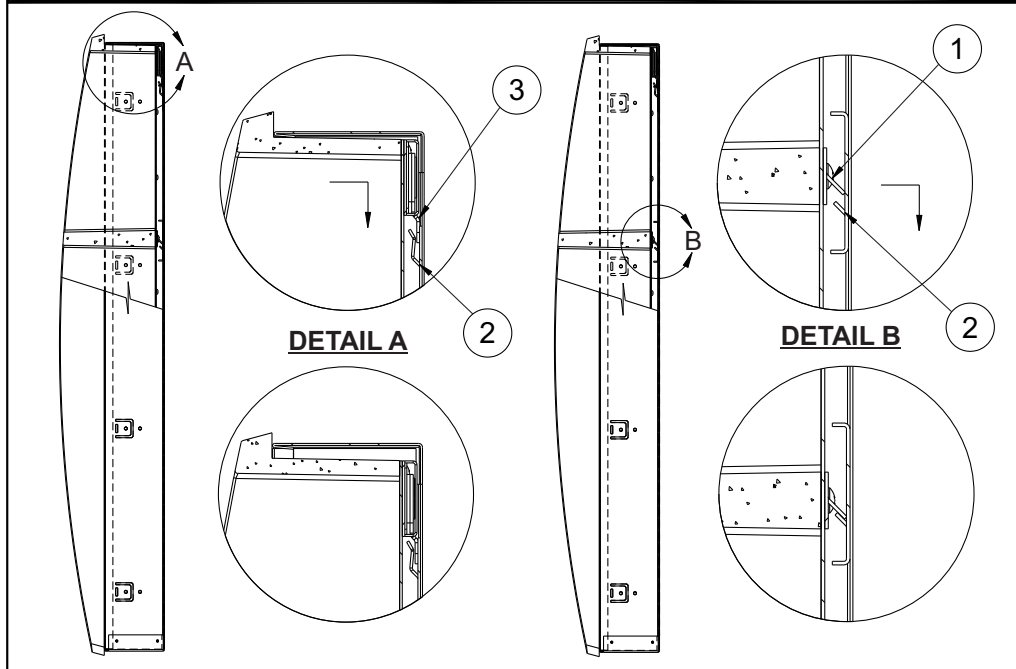

- 1 Back Panel Mounting Clip
- 2 Frame Mounting Channel
- 3 Magnetic Latch

**4** Secure Magnetic Latch using Magnet Key (Provided) by engaging Latch and moving it in one of two directions depicted by the arrows below.

- 1 Magnetic Latch
- 2 Frame Mounting Channel
- 3 Magnet Key (Provided)
- 4 Shelf Assembly

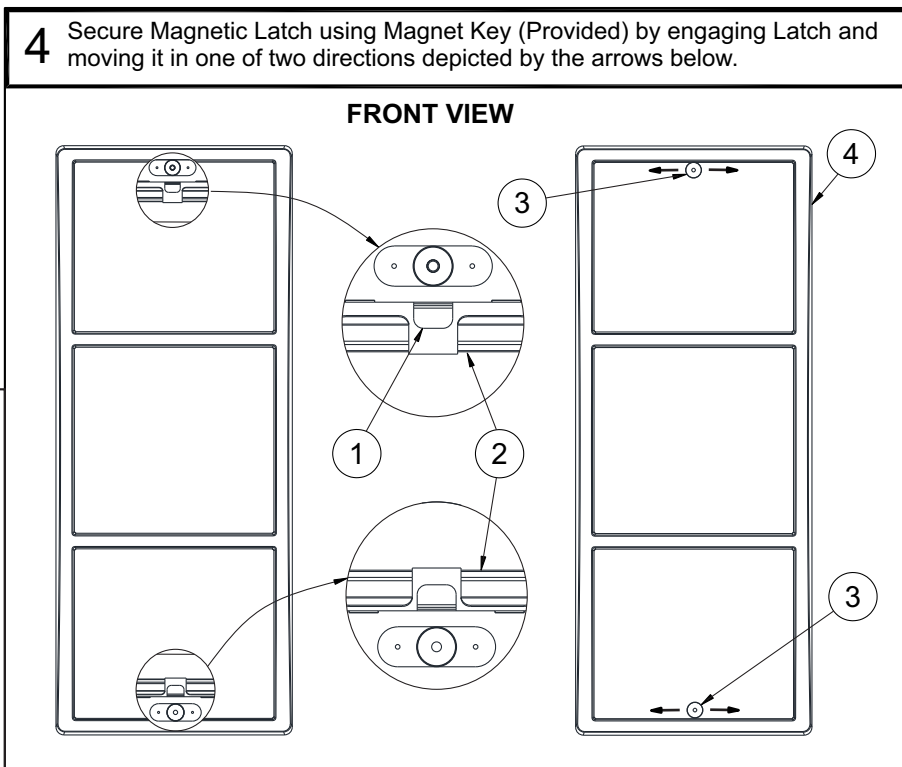
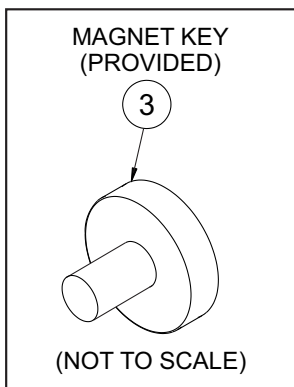

**NOTE: IF MOUNTED HORIZONTALLY, USE MAGNET KEY TO ENGAGE LATCH AND MOVE TOWARDS THE DIRECTION OF GRAVITY TO ENSURE THE FIXTURE IS SECURE.**



## **MAINTENANCE**

CARE, CLEANING, AND REPAIR OF CORTERRA SOLID SURFACE

### **CORTERRA SOLID SURFACE**

Acorn's densified solid surface material is composed of recycled solid-surface polymer resin, aluminum trihydrate and fillers. It is resistant to stains, impact and burns and complies with ANSI Z124.3. It is attractive, durable and easy to maintain.

### **ROUTINE CLEANING**

Corterra should be kept clean at all times. If maintained, Corterra surfaces will retain their new, clean appearance indefinitely. Wash with a non-abrasive all purpose cleaner and water, then rinse. Wipe dry. (Never use cleaners with strong chemicals such as toilet bowl cleaners, rust removers, ceramic cook top cleaners, laquer thinners or oven cleaners). To remove persistent stains use a Scotch Brite pad and an abrasive cleaner or a solution of household bleach and water (1 part water to 1 part bleach).

### **REPAIRING SURFACE DAMAGE**

Surface damage, such as minor chips, scratches, burn marks and graffiti can be repaired with a fine grit abrasive cleanser, such as a Scotch-Brite pad or fine grit sandpaper. For more serious physical damage caused by vandals, an Acorn Solid Surface Repair Kit is available. Contact the factory for details. Refer to drawing #9927-160-002.