



Division of
Acorn Engineering Company



A MEMBER OF



Use



L Series 75 Gallon Mobile Cold Tank

75-L-M-TO



75-L-M-TO-EG10

May Show Some Available Options

Whitehall 75-L-M-TO Mobile Cold Tank

Cold Tank Capacity is 75 gallons.

Cold Tank is 52"L x 24"W x 18"D and is seamless welded construction, fabricated from heavy gauge, type 304 stainless steel, polished to a satin finish. Cold Tank rim is reinforced with a concealed stainless steel rod. Cold Tank bottom is a seamless, coved (rounded) design for effective cleaning.

Heavy Duty Swivel Casters support all mobile models. Rear pair of casters are lockable for stabilizing during Cold Tank use.

Drain option -SDP has a bottom drain, leading to a separate, concealed water evacuation pump. A hose is attached to the side of the unit to facilitate the evacuation.

GUIDE SPECIFICATIONS

Provide Whitehall Mobile Cold Tank (specify model number and options) with a 75-gallon capacity, 52"L x 24"W x 88"D. Cold Tank shall be fabricated from heavy gauge, type 304 stainless steel. Construction shall be seamless welded and exposed surfaces shall be polished to satin finish. Bottom of Cold Tank shall be a seamless, rounded coved design. Cold Tank shall have heavy duty swivel casters with locking device on rear pair of casters.

Please visit www.whitehallmfg.com
for most current specifications.





MODEL NUMBER AND OPTION SELECTIONS

Capacity

-75 Gallons

Series

L Lo-Boy Series

Type

-M Mobile Cold Tank

Suffix Options (See Cold Tank Options Section for Details)

- ADH Auxiliary Drain Hose Assembly
- AS3 Adjustable Suspension Seat
- EG Enviro-Glaze® Color Powder Coating - Specify Color: _____
<https://www.whitehallmfg.com/enviro-glaze>
- GFI Ground Fault Interrupter
- HR Head Rest, Adjustable
- LOGO Applied Logos: Team, Facility, Company Logo
- RS Reclining Seat
- SDP Separate Drain Pump
- TTS2 Tank Top Seat

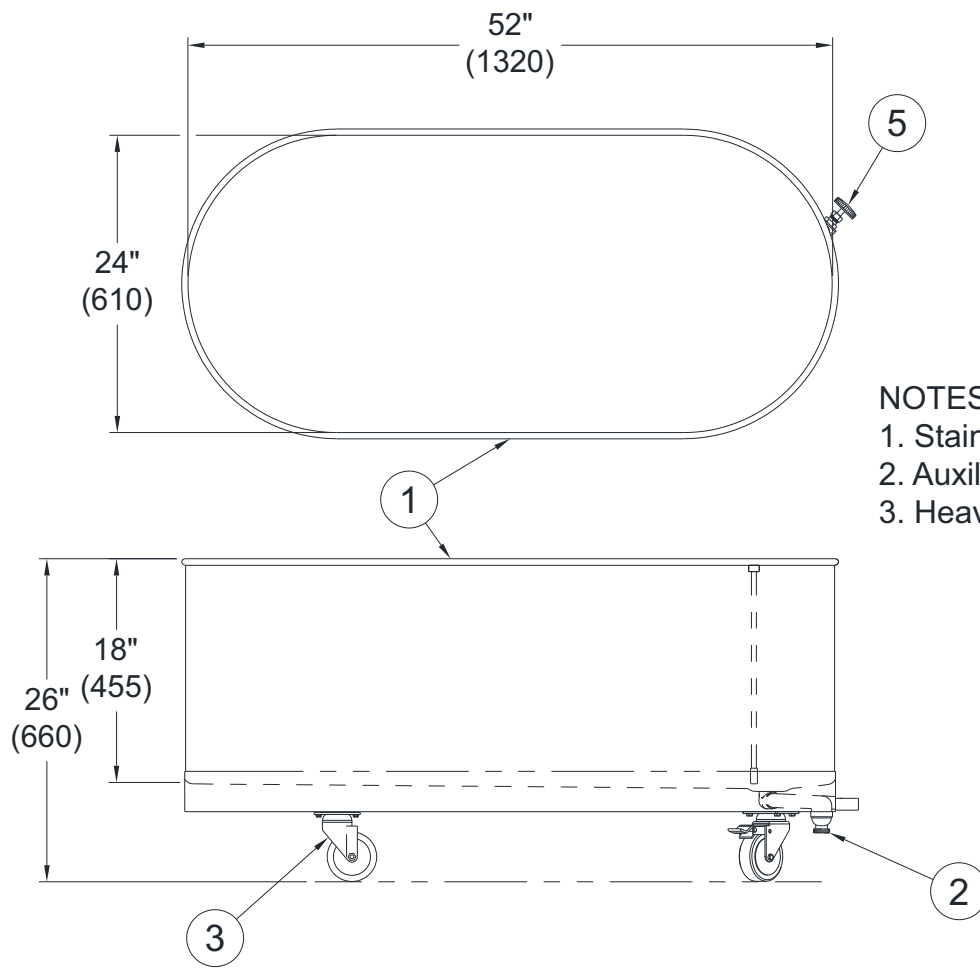

NOTES:

1. Stainless Steel Cold Tank
2. Auxiliary Drain Valve
3. Heavy Duty Swivel Casters

MOBILE L-75-M SERIES COLD TANK

⚠ WARNING: Cancer and Reproductive Harm - www.P65Warnings.ca.gov

All dimensions are nominal and subject to manufacturer's change without notice. Whitehall assumes no responsibility for use of void or superseded data © Whitehall Manufacturing, Member of Morris Group International. Please visit www.whitehallmfg.com for most current specifications.

SELECTION SUMMARY & APPROVAL FOR MANUFACTURING

Model Number & Options _____ Quantity _____
 Company _____ Date _____
 Contact _____ Title _____
 Approval for Manufacturing/Signature _____